

MODEL : SLK-TE12X Series

Receipt Printer User's Manual



Disposal of Old Electrical&Electronic Equipment(Applicable in the European Union and other European countries with separate collection systems)

본 제품을 분류되지 않은 자치단체 쓰레기로 처리하지 마십시오,
본 제품은 재활용이 가능하며, 해당 지역의 기준에 따라 재활용해야 합니다.

Table of Contents

1. Parts Identifications	3
2. Setting up the printer	4
2.1 Unpacking	4
2.2 Connecting the cables	5
2.3 Loading the roll paper	9
2.4 Adjustment of paper width	12
3. Control panel and other functions	13
3.1 Control panel	13
3.2 Error Indicating	13
4. Self Test	14
5. ASCII Print	15
6. Select Baudrate Mode	15
7. Hexadecimal Dump	16
8. Printer cleaning	17
9. Specifications	18
9.1. General Specifications	18
9.2. Auto Cutter Specifications	20
9.3. Interface	20
9.4. Electrical Characteristics	20
9.5. Environmental Requirements	21
9.6. Reliability	21
9.7. Certification	21
10. Command List	22

1. Parts Identifications

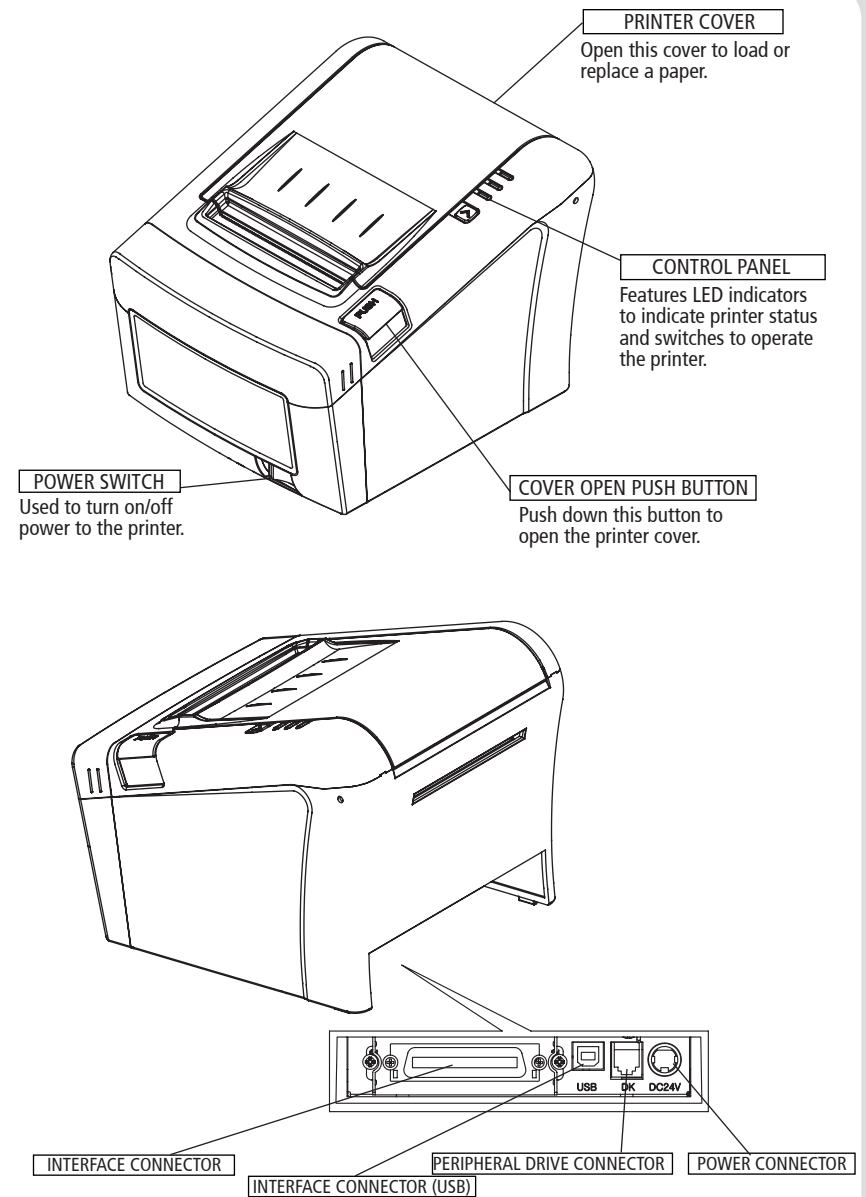

2. Setting Up the Printer

2-1. Unpacking

Your printer box should include these items. If any items are damaged or missing, please contact your dealer for assistance.

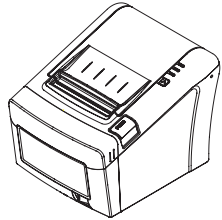

The Printer



CD

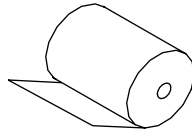

Roll Paper

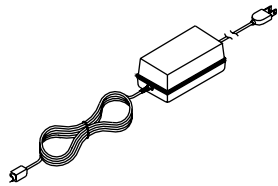

Adaptor(Optional)



Interface Cable(optional)

2-2. Connecting the Cables

All cables connect to the connector panel on the back of the printer which is shown below:

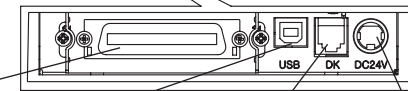
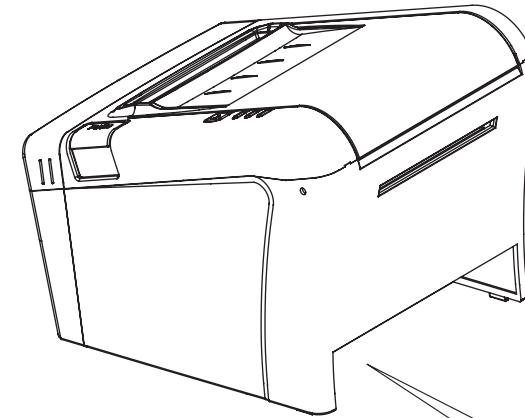

INTERFACE CONNECTOR

For connection to a host computer.

INTERFACE CONNECTOR (USB)

For connection to a host computer.

PERIPHERAL DRIVE CONNECTOR

Connects to peripheral units such as cash drawer, etc.
Do not connect this to a telephone.

POWER CONNECTOR

For connection of the AC adapter.
Never unplug the AC adapter while the printer is on.

Before connecting any of the cables, make sure that both the printer and the computer are turned off.

2-2-1. Interface Connector

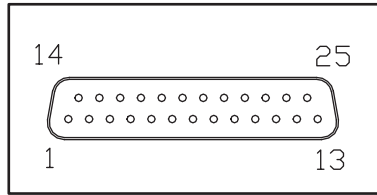

<D-SUB 25 Female Serial>

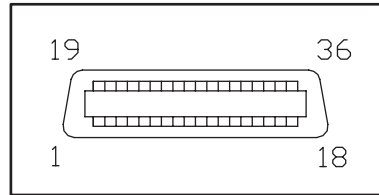

<Centronics Parallel>

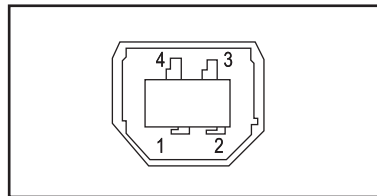

<USB "B" Type>

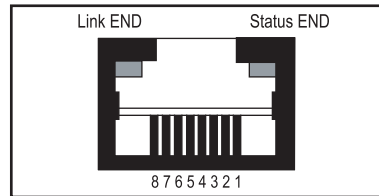

<Ethernet>

USB Interface

Pin	Signal	I/O	Description
1	+5V	-	+5V
2	DATA-	-	Printer transmit data line
3	DATA+	-	Printer transmit data line
4	GND	-	System Ground

Serial Interface

PIN	SIGNAL	I/O	DESCRIPTION
2	TxD	Output	Printer transmit data line RS-232C level
3	RxD	Input	Printer receive data line RS-232C level
4, 20	DTR	Output	Printer handshake to host line RS-232C level
6	DSR	Input	Data Send Ready
1, 7	GND	-	System Ground

Centronics Parallel Interface

PIN	SIGNAL	I/O	DESCRIPTION
1	STROBE-	Input	Synchronize signal Data received
2~9	DATA 0~7	Input/Output	Data bit Transmitted 0~7
10	ACK-	Output	Data receiving completed.
11	BUSY	Output	Impossible to print of data receiving.
12	PE	Output	Paper empty
13	SELECT	Output	Printer status for ON/OFF line
14	AUTO FEED-	Input	Paper auto feed signal
15	GROUND	-	System ground
16	GROUND	-	System ground
17	NC	-	
18	LOGIC-H	-	+3.3V
19~30	GROUND	-	System ground
31	INIT-	Input	Initialize
32	ERROR-	Output	Printer error
33	GROUND	-	System ground
34	NC	-	
35	NC	-	
36	SELLECT IN-	Input	Printer select signal

Ethernet Interface

PIN	SIGNAL	I/O
1	Data Out +	Output Data +
2	Data Out -	Output Data -
3	GND	Ground
4	Data IN +	Input Data +
5	Data IN -	Input Data -
6	N.C	
7	N.C	
8	N.C	

2-2-2. Cash Drawer Connector

The printer can operate two cash drawers with a 6 pin RJ-11 modular connector.

The driver is capable of supplying a maximum current of 1.0A for 510ms or less when not printing.

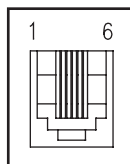

PIN	SIGNAL	DESCRIPTION
1	Signal GND	-
2	Drawer kick-out drive signal 1	Output
3	Drawer open/close signal	Input
4	+24V	-
5	Drawer kick-out drive signal 2	Output
6	Signal GND	-

2-3. Loading the Roll Paper

Notes: Be sure to use paper rolls that meet the specifications. Do not use paper rolls that have the paper glued to the core because the printer cannot detect the paper end correctly.

♣ Turn off power switch.

1. Make sure that the printer is not receiving data; Otherwise, data may be lost.

2. Open the paper roll cover by pushing down the cover open push button.

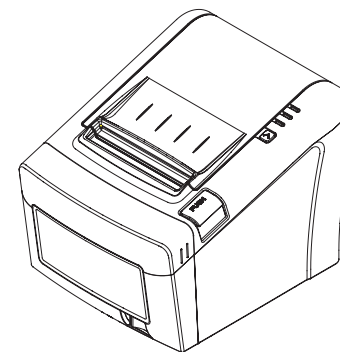

3. Remove the used paper roll core if there is one inside.

4. Insert new paper roll as shown.

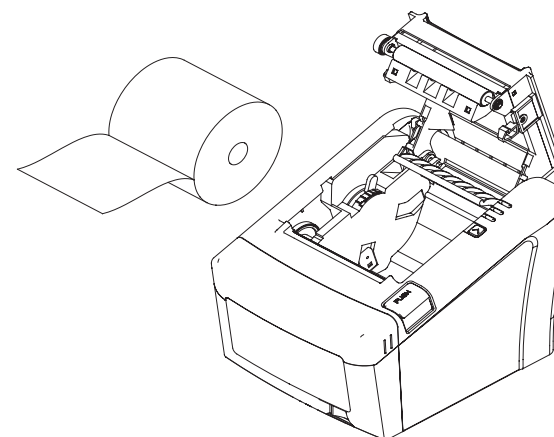

5. Note the correct direction that the paper comes off the roll:

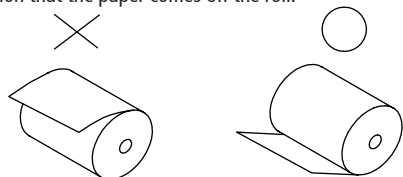

6. Pull out a small amount of paper as shown. Then, close the cover.

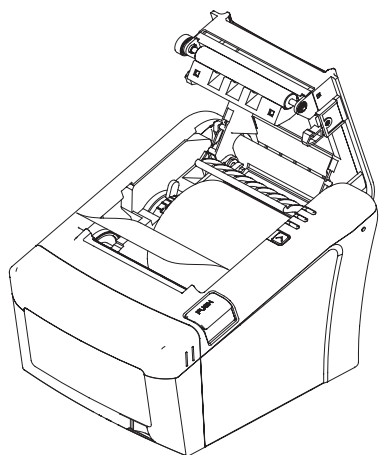

7. Tear off the paper as shown.

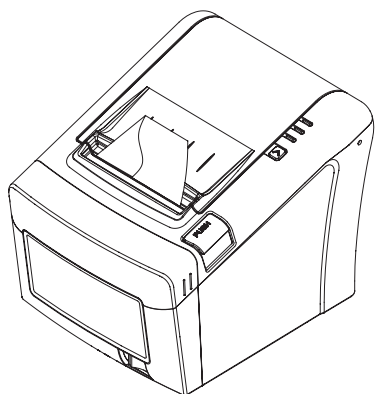

♣ CAUTION:

When the paper cutter is jammed, the top cover might be stuck closed. In this case, repeat power on and off several times. If the top cover is still stuck, please follow the steps to release the paper jam.

1. Make sure the printer is turned off.
2. Take out cutter cover as shown.

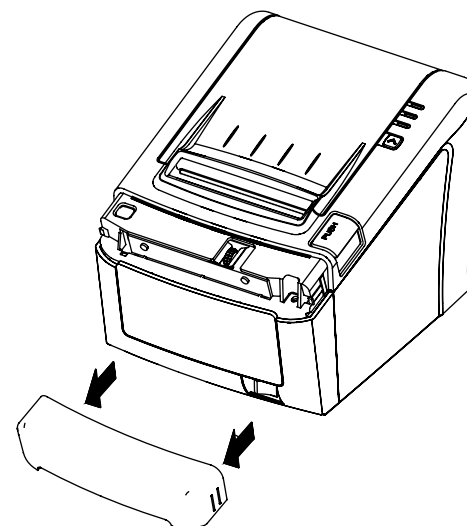

3. Turn the knobble with your finger to clear the paper jam at cutter.

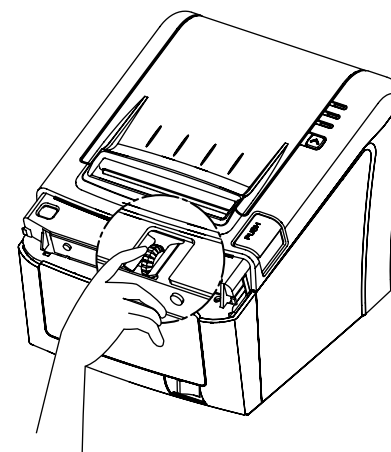

2-4. Adjustment of paper width

1. Please adjust the Paper Guide to fit to the paper width as the direction of arrow.

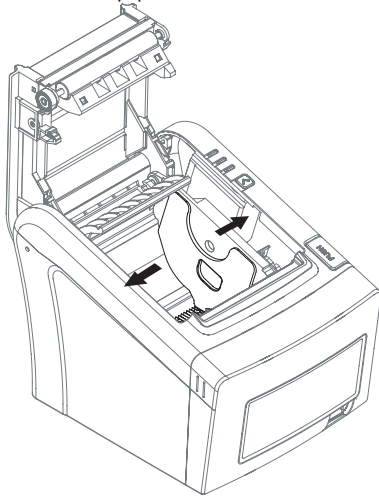

2. Tight the screw after adjusting the Paper Guide.

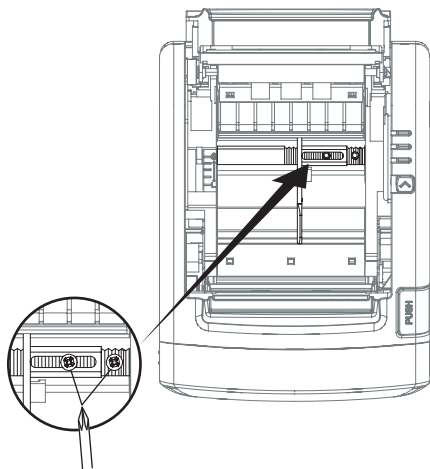

3. Pull the edge of paper once the paper roll is installed correctly and close the Paper Cover.

3. Control panel and other functions

3-1. Control panel

You can control the basic paper feeding operations of the printer with the button on the control panel. The indicator lights let you to monitor the printer's status.

Control Panel

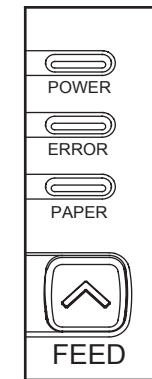

Button

The button can be disabled by the ESC c 5 command.

Press the FEED button once to advance paper one line. You can also hold down the FEED button to feed paper continuously.

3-2. Error indicators

This section explains the different patterns signaled by the two LED indicators located on the top cover of the printer.

STATUS	PAPER	ERROR	POWER	REMARKS
	RED	RED	GREEN	
Power off	OFF	OFF	OFF	Normal power is not supplied to the printer
Power on	OFF	OFF	ON	Normal power is supplied to the printer
On line	OFF	OFF	ON	Normal error-free mode
Cover open	OFF	ON	ON	Close cover
Paper empty	OFF	ON	ON	Insert new paper roll
Paper near end	ON	OFF	ON	Paper is low
Test mode	OFF	OFF	ON	Ignored error led

4. Self Test

The self-test result indicated whether the printer is operating properly. Also with this, user can check following options or status of the printer.

- Control circuit
- Printer mechanism
- Printing quality
- ROM version
- Interface setting

This test is independent of any other equipment or software.

Running the self test

1. Make sure the printer is turned off and the printer cover is closed properly before performing the self test
2. Turn the printer on holding the FEED button, then the self-test will start. The self-test prints the printer setting value and then prints the following, and pauses. (Error LED On)

SELECT MODE BY BUTTON

1. ASCII PRINT
2. SELECT BAUDRATE MODE
3. HEXADUMP MODE

3. Press the FEED button consecutively (1~3)

1. ASCII PRINT (press the FEED button once)	2. SELECT BAUDRATE MODE (press the FEED button twice)	3. HEXADUMP MODE (press the FEED button triple time)
Printing test page constructed with ACII code.	Set the speed of Serial Interface (You can set the BAUDRATE in this mode)	Printing the HEX value received from the interface

♣Wait for 5~6 seconds if you want to exit. Printer performs a cutting when exiting this mode

4. The printer is ready to receive data after finishing setting.

5. ASCII Print

ASCII PRINT is printing a test page constructed ASCII code. You can able to check the printer works properly with this

The ASCII PRINT test automatically ends and cuts the paper after printing the following:

***** Completed *****

The printer is ready to receive data as soon as it completes the ASCII PRINT.

6. Select Baudrate Mode

After entering the BAUDRATE MODE, the list which can select the BPS will be printed. Similar like Self Test, you can press the FEED button to select a BAUDRATE.

Once the input performs properly, the printer shows a result and store.

The printer is ready to receive data as soon as it completes the SELECT BAUDRATEMODE.

SELECT BAUDRATE BY BUTTON

1. 9600bps
2. 19200bps
3. 38400bps
4. 115200bps

7. Hexadecimal Dump

This feature allows experienced users to see exactly what data is coming to the printer. This can be useful in finding software problems.

When you go into the hex dump function, the printer prints all commands and other data in hexadecimal format along with a guide section to help you find specific commands.

To use the hex dump feature, follow these steps

1. Please turn printer off.
2. Please turn printer on while press down "Feed" button.
3. Press the FEED button three times when the Self Test printed.
4. Now printer had entered into Hexa dump mode.
5. Run any software program that sends data to the printer. The printer prints "Hexadecimal printing mode..." and then all the codes it receives in a two-column format. The first column contains the hexadecimal codes and the second column gives the ASCII characters that correspond to the codes.

Hexadecimal Dump

```
1B 21 00 1B 26 02 40 40 .!.& . @ @
1B 25 01 1B 63 34 00 1B .%..c4 ..
41 42 43 44 45 46 47 48 ABCDEFGH
```

A period (.) is printed for each code that has no ASCII equivalent.

6. Turn off the printer.
7. Turn on the printer.

8. Printer cleaning

If the interior of the printer is dusty, printing quality can be lowered. In this case, follow the instructions below to clean the printer.

♣Note :

1. Make sure to turn the printer power off prior to cleaning
2. Regarding print head cleaning, as the print head is very hot during printing, turn off the printer power and wait approximately 10 minute before start.
3. When cleaning the print head, take care not to touch the heated part of the print head. The print head subject to be damaged by static electricity.
4. Take care not to allow the print head to become scratched and /or damaged in any way.

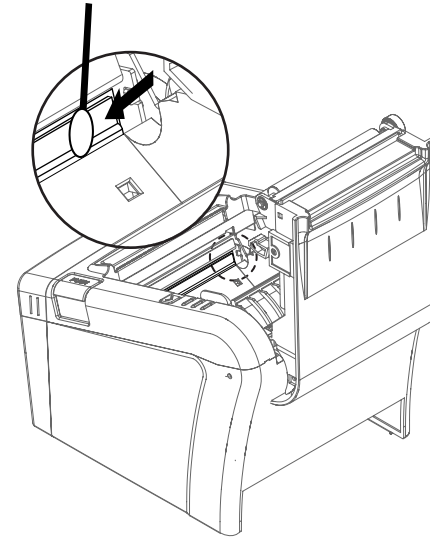

1. Use an applicator swab moistened with an alcohol solution to clean the print head and remove any dusts.
2. Once the cleaning is completed, insert paper roll into the printer few minutes later and close the printer cover.

♣Preventing Overheating

To prevent the motor from overheating, continuous operation of the printer should be 1.5 m or less in print length. Set the pause time for 30 seconds or more than it.

9-2. Auto Cutter Specifications

(1) Cutting Frequency Max. 30 cuts per minute

(2) Thickness of paper 0.06 ~ 0.09 mm

(3) Cutter Life (if the paper thickness is between 65 and 80µm)

SLK-TE121	SLK-TE122
1.5 million cuttings	1.8 million cuttings

9-3. Interface

RS232 Serial Interface, Centronics Parallel Interface(IEEE1284), USB Interface, Ethernet Interface(100Mbps)

9-4. Electrical Characteristics

(1) Input Voltage DC 24V ± 10%

(2) Current Consumption Operating: Approx. 1.5 A (at ASC II printing)
 Peak : Approx. 10 A
 (at print duty 100%, For 10 seconds or less)
 Stand-by : Approx. 0.03 A

(3) Power Connector

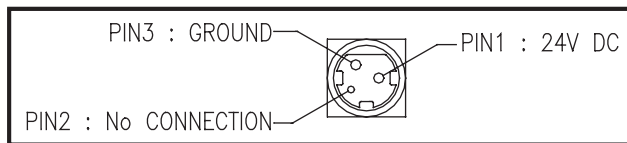

9-5. Environmental Requirements

(1) Operating

Temperature 0°C to 45°C

Humidity 10% to 90% RH (without condensation)

(2) Transport/Storage (except paper)

Temperature -20°C to 60°C

Humidity 10% to 90% RH (without condensation)

9-6. Reliability

(1) MCBF 50 million lines (based on an average printing rate of 12.5% with paper thickness in the range 65µm to 75µm)
 35 million lines (based on an average printing rate of 12.5% with paper thickness in the range 76µm to 150µm)

(2) Head Life 100 million pulses, 150Km

(3) Cutter Life (if the paper thickness is between 65 and 80mm)

SLK-TE121	SLK-TE122
1.5 million cuttings	1.8 million cuttings

9-7. Certification

(1) FCC PART15 CLASS A

(2) UL/cUL (UL 60950-1)

(3) KC

(4) CE-EMCD (CE-EMCD Class B should use Parallel shield Cable complied with IEEE-1284 standards)

(5) ENERGY STAR

This equipment is indoor use and all the communication wirings are limited to inside of the building.

PATENT



